

HELICOPTER TROOPING BRIEFING



Oryx Helicopter Information



- Twin engine - 1400 kW each
- MAUW 8000 kg
- Cruise 240 km/h
- 1200 kg / 1700 kg Fuel
- 480 kg Fuel per hour
- 600 km / 850 km Range



AIRCRAFT COMMANDERS AUTHORITY

- In matters relating to the flying, handling and general safety of the aircraft and occupants, the commander has full authority over all occupants irrespective of rank.
- LMU 3 VOL 2 PART 8 SECT 4
CHAPTER 4.

SAFETY PRECAUTIONS.

Emergency landing

- **Remain calm!**
- **Head between the knees.**
- **Remain seated in aircraft until rotors have stopped.**
- **Exit bearing safety areas in mind.**

Emergency exits: Main sliding door



EMERGENCY EXITS: CABIN WINDOWS



- Perspex.
- Can be forced out

EMERGENCY EXITS: ESCAPE HATCH



EMERGENCY EXITS: ESCAPE HATCH



- Force out perspex.

LOOSE ARTICLES

- **Jackets and clothing.**
- **Caps.**
- **Spectacles.**
- **FIREARMS. (Butts, Safe & Barrel direction)**

CELLULAR PHONES

- **Off !!**
- **A/C systems and radios are affected**

SAFETY AREAS

- **Enplaning and deplaning: await permission from the crew.**
- **Always use 10 to 2 o'clock safety zone.**
- **Never pass behind DOOR line!!**
- **Never approach TAIL ROTOR!!**

SAFETY AREAS

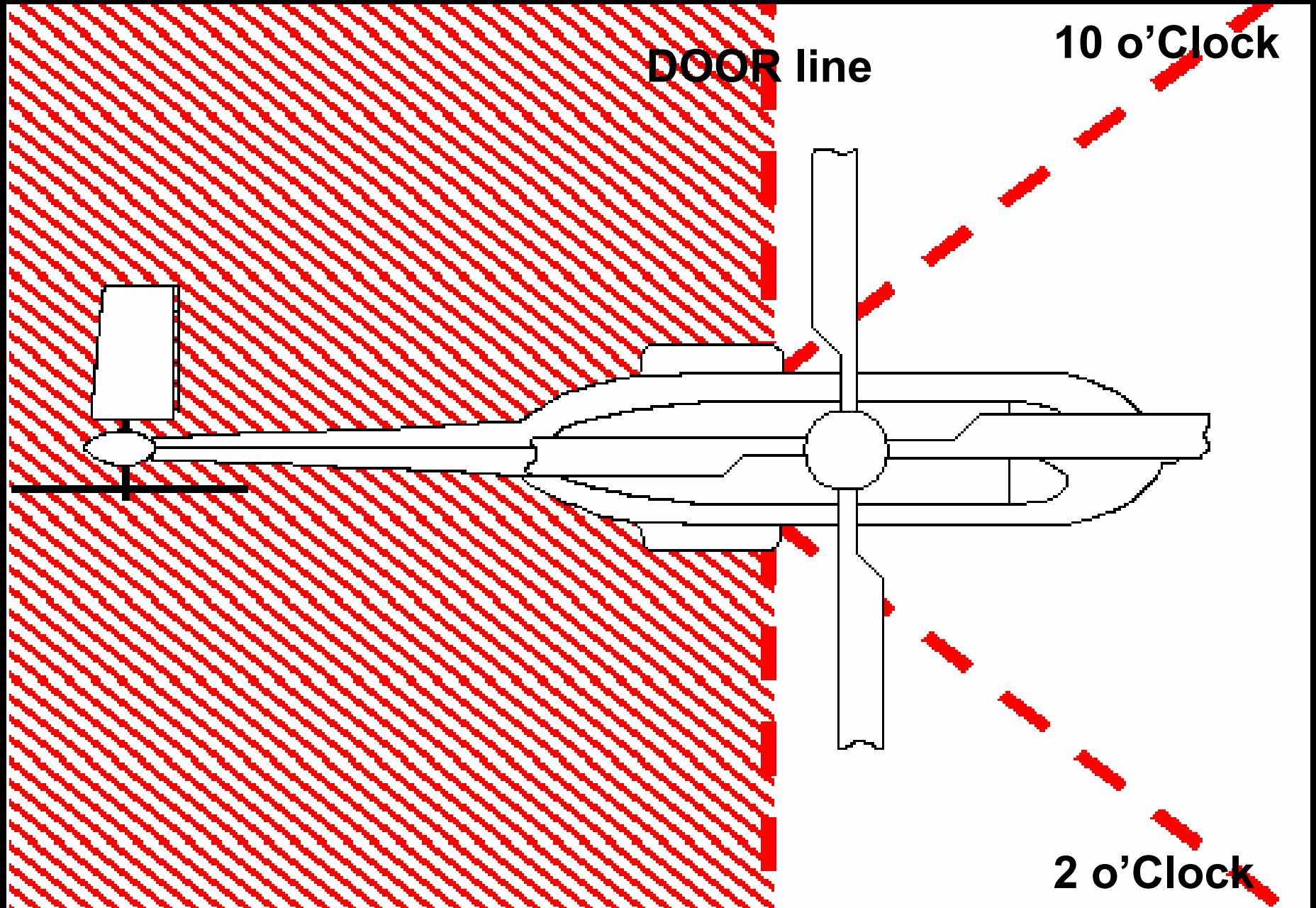

ENPLANING

- Maintain visual on Pilots.
- Only approach the aircraft once given signal to do so within safety area.
- Aerials are folded and weapons are facing away from the aircraft.
- Backpacks

FLOOR

- **Sharp objects.**
- **No Weapons on floor.**
- **Flight engineer in command over the rear of aircraft. Keep him visual at all times.**

SEATING

- **Section leader aids boarding**
- **First members to enplane move to rear**
- **Seating- face forward open legs**
- **Weapons barrel on foot-Barrel facing down**
- **Once stick seated move forwards**

DEPLANING

- **F/Eng give 5 & 1 min Warning prior to landing**
- **Only deplane once F/Eng gives signal**
- **Safety is own responsibility during exit**
- **Section leader to ensure no equipment remains in aircraft**
- **Slopes-DANGER**
- **Do not use step during deplaning-
INJURIES**

AIR SICKNESS BAGS



GENERAL

- **Indemnity forms and passenger lists: remain with allocated aircraft.**
- **If rotors are turning, Flight engineer to accompany passengers to and from aircraft.**
- **Any problems, attract F/E attention.**
- **No toilet facilities available on aircraft!**